

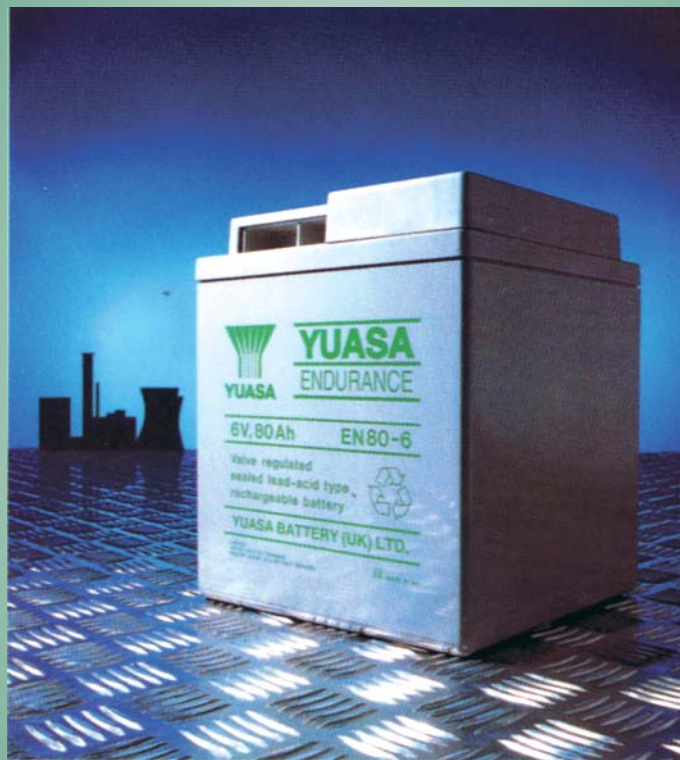

ENDURANCE
BATTERIES



VALVE REGULATED
RECHARGEABLE
BATTERIES

contents...

C O N T E N T S

Introduction	4
Typical Applications	4
Construction	4
Features	5
Sizing Combinations	6
Gas Recombination Mechanism	7
General Specifications	10
Performance Data 'Amps'	11
Performance Data 'Watts'	12
Discharge	13
Charging	14
Test	19
Design Life	19
Inspection and Handling	21
Cautions	22
Installation Services	23
Battery Racks	24
Glossary	25

INTRODUCTION

The YUASA 'Endurance' range of sealed lead acid batteries has been designed to meet the expanding requirements of supplying power for communications, emergency power supplies and many other applications.

YUASA Endurance range fully compliant with IEC 896-2.

YUASA Endurance Batteries have been designed and tested to ensure full compliance with BS 6290 Part 4 (1997) and require virtually no maintenance throughout the designed service life of 10 years plus.

TYPICAL APPLICATIONS

- ❖ Telephone Exchanges
- ❖ Telecommunications
- ❖ Uninterruptible Power Supplies (UPS)
- ❖ Emergency Lighting
- ❖ Alarm Systems
- ❖ Security Systems
- ❖ Computers

CONSTRUCTION

YUASA Endurance Batteries are designed so that the necessary quantity of electrolyte is absorbed within the plates and separators making it possible through gas recombination technology to provide a valve regulated lead acid battery, commonly referred to as sealed or maintenance free.

The construction and features of YUASA Endurance Batteries are shown in Fig. 1 and Table 1 respectively.

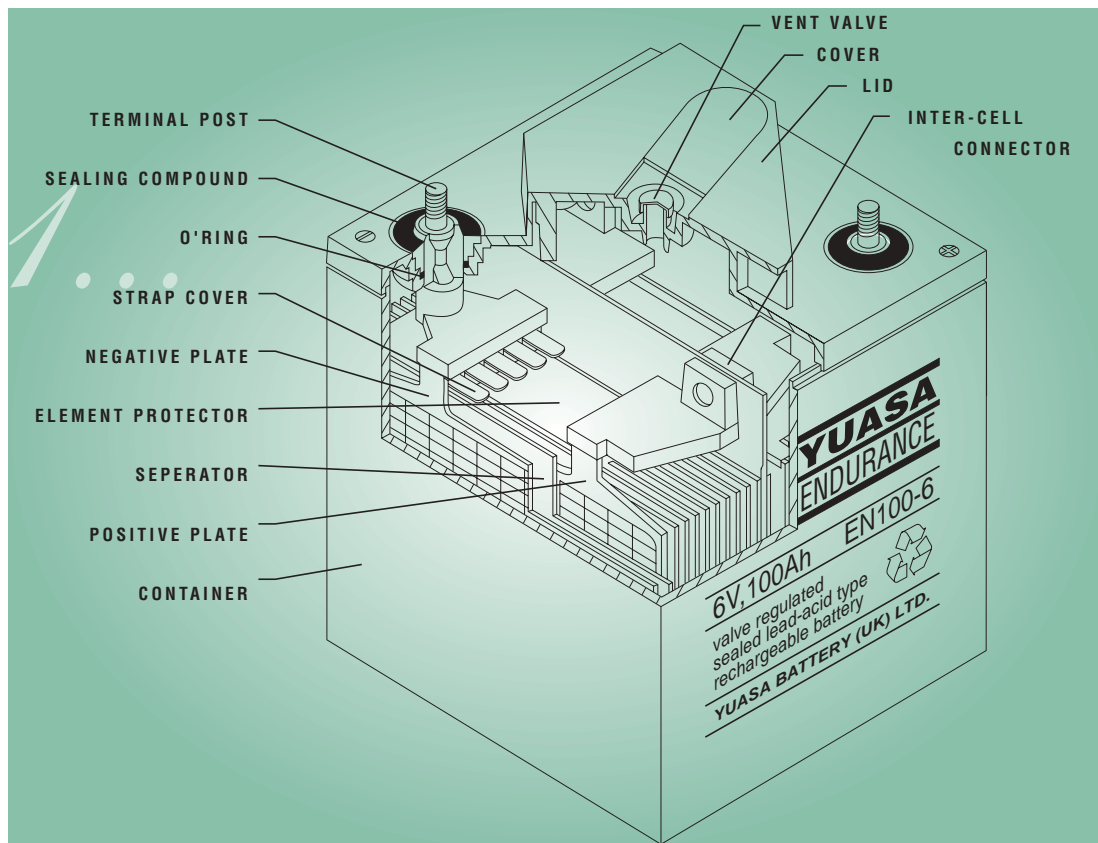

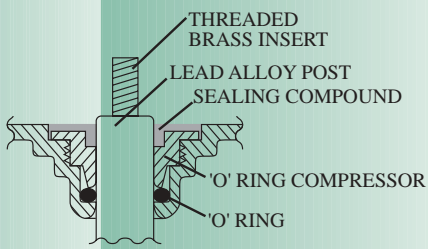

table 1...

PARTS	MATERIAL	FUNCTION
Positive and negative plates	Heavy duty anti-corrosive lead calcium alloy grids pasted with active material	<ul style="list-style-type: none"> ❖ Retain sufficient capacity ❖ Maintain capacity performance throughout design life ❖ Minimize self-discharge
Separator	Microfine fibre mat with excellent heat oxidation properties	<ul style="list-style-type: none"> ❖ Prevents short circuit between (+) & (-) plates ❖ Retains electrolyte ❖ Prevents active material shedding
Electrolyte	Dilute sulphuric acid fully absorbed by plates and separators	<ul style="list-style-type: none"> ❖ Causes electro chemical reaction in (+) and (-) plates
Case components: container, lid, vent cover and battery cover	Injection moulded flame retardant ABS polymer	<ul style="list-style-type: none"> ❖ Provides heat sealed compartment for 2V cell groups ❖ Withstands thermal and mechanical shock ❖ Integral lifting handle incorporated into lid design for ease of handling
Intercell connectors	Heavy duty anti-corrosive lead alloy, squeeze welded together through the container wall	<ul style="list-style-type: none"> ❖ Interconnect positive plates of 1 cell with negative plates of adjoining cell ❖ Transmits battery power from plates to battery terminals ❖ Capable of carrying ultra high current even total short circuit load
Safety vent valve	Synthetic rubber moulded cap 	<ul style="list-style-type: none"> ❖ Releases gas if internal pressure rises abnormally high ❖ Normalises internal pressure ❖ Prevents air ingress
Strap cover	Moulded polypropylene	<ul style="list-style-type: none"> ❖ Prevents short circuit due to positive plate growth
Terminal		<ul style="list-style-type: none"> ❖ Provides maximum conductivity enhancing high rate discharge characteristics ❖ Provides dual-seal construction of 'O'-ring and sealing compound to ensure a perfect seal ❖ 8 mm thread insert allows easy installation

FEATURES

FLAME RETARDANT The container, lid, valve cover and final battery cover are moulded in high flame retardant ABS.

WELDED LID/CONTAINER The lid and container are joined together by means of a heat seal producing a high integrity weld between container and lid.

SEALED CONSTRUCTION No electrolyte leakage will occur from battery terminals or case, ensuring safe and efficient operation.

LOW MAINTENANCE Endurance Batteries utilise the gas recombination system which transforms the generated gas into water, thus no topping up is required throughout the life of the battery.

FEATURES (Cont.)

ELECTROLYTE SUSPENSION	Endurance batteries can be mounted in any orientation since all electrolyte is retained within the battery plates and separators. (Excluding continuous use inverted.)
VENTING SYSTEM	In the event of overcharge the Endurance batteries are fitted with a safe low pressure venting system which automatically reseals after releasing any excess pressure.
LONG LIFE	Heavy duty lead calcium alloy grids and intercell connectors with anti-corrosive construction enable the Endurance Batteries to remain in service for a design life of 10 years.
NO EQUALISING CHARGE	No equalising charge is required during normal float charge operation.

SIZING COMBINATIONS

PARALLEL CONNECTION Endurance batteries have been specifically designed so as to allow parallel networks of different capacity to be used within a common system. This greatly extends the selection of capacities that can be achieved.

Each Endurance battery has been designed using a common plate size with a nominal capacity of 20Ah per plate. For example, the EN100 (100Ah) is constructed using five of the 20Ah plates per cell, whereas the EN480 (480Ah) utilises twenty-four 20Ah plates per cell. This simplistic design strategy, therefore, allows any multiple parallel combination of the basic model range.

The following list, details some of the possible capacity variations that can be achieved utilising the base Endurance models:

chart 1...

AH CAPACITY REQUIRED	ENDURANCE PARALLEL STRING COMBINATIONS
80	EN80
100	EN100
160	EN160
180	EN80 + EN100
200	EN100 x 2
240	EN80 x 3
260	EN100 + EN160
300	EN100 x 3
320	EN320
400	EN100 x 4
420	EN100 + EN320
480	EN480
500	EN100 x 5
580	EN100 + EN480
640	EN320 x 2
ETC/ETC	
2020	EN480 x 4 + EN100
2080	EN480 x 4 + EN160
2240	EN480 x 4 + EN320
2400	EN480 x 5

Notes

1. This design feature is only particular to the Endurance range.
2. Endurance batteries should not be connected in parallel to any other makes or ranges of batteries.
3. Only parallel mixing is allowed, no battery types including the Endurance range should be mixed in SERIES strings.

The chemical reaction taking place in a lead-acid storage battery is as shown in the formula:

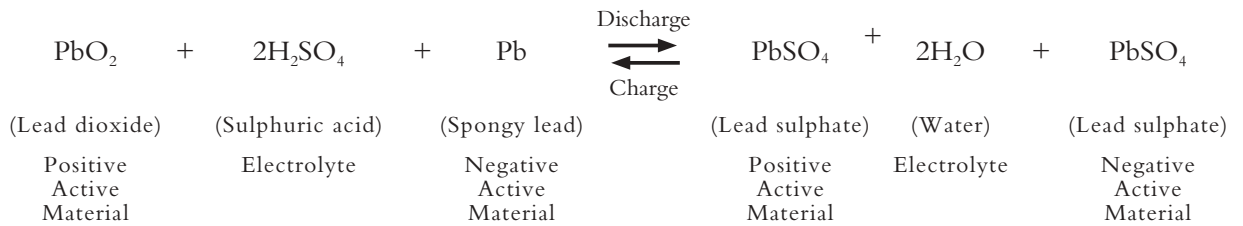

At discharge lead dioxide in positive plates and spongy lead in negative plates react with sulphuric acid in the electrolyte and gradually transform into lead sulphate, during which the sulphuric acid concentration decreases.

Conversely, when the battery is charged, the positive and negative active materials which had been turned into lead sulphate gradually revert to lead dioxide and spongy lead respectively, releasing the sulphuric acid absorbed in the active materials, during which the sulphuric acid concentration increases, as shown in Fig. 2.

When battery charging approaches its final stage, the charging current is consumed solely for electrolytic decomposition of water in the electrolyte, resulting in generation of oxygen gas from positive plates and hydrogen gas from negative plates. The generated gas will escape from the battery causing a decrease of the electrolyte, thereby requiring occasional water replenishment.

However, YUASA Endurance Batteries utilise the characteristics of spongy lead, or negative active material, which is very active in moist conditions and reacts very quickly with oxygen, thereby suppressing the decrease of water eliminating the need of water replenishment.

REACTION FROM BEGINNING OF CHARGE TO BEFORE THE FINAL STAGE

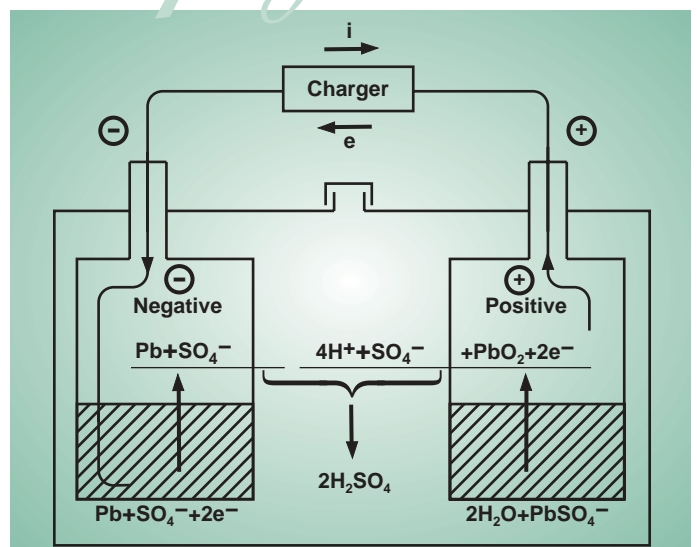

The process of charging from its beginning to the final stage is identical with that of conventional batteries as shown in Fig. 2.

On the one hand, after the final stage of charging or under overcharge condition, the charging energy is consumed for electrolytic decomposition of water, and the positive plates generate oxygen gas which reacts with the spongy lead in negative plates and the sulphuric acid in electrolyte, turning a part of negative plates into a discharged condition, thus suppressing the hydrogen gas generation from negative plates.

The part of negative plates which had turned to discharged condition through reaction with oxygen gas is then reverted to original spongy lead by subsequent charge. Thus, a negative plate keeps equilibrium between the amount which turns into spongy lead by charging and the amount of spongy lead which turns into lead sulphate through absorbing the gas generated from positive plate, which makes it possible for the battery to be of a sealed type.

The chemical reaction which takes place after the final stage of charging or under overcharge condition is as shown in Fig. 3 and the reaction formula is described below

① Reaction at positive plate (oxygen generation)

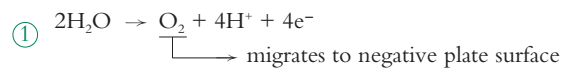

② Reaction at negative plate

② (chemical reaction of spongy lead with oxygen)

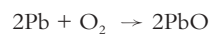

③ (chemical reaction of PbO with electrolyte)

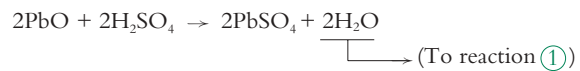

④ (Reduction of PbSO₄)

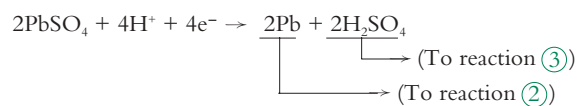

Total reaction at negative plate

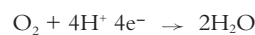

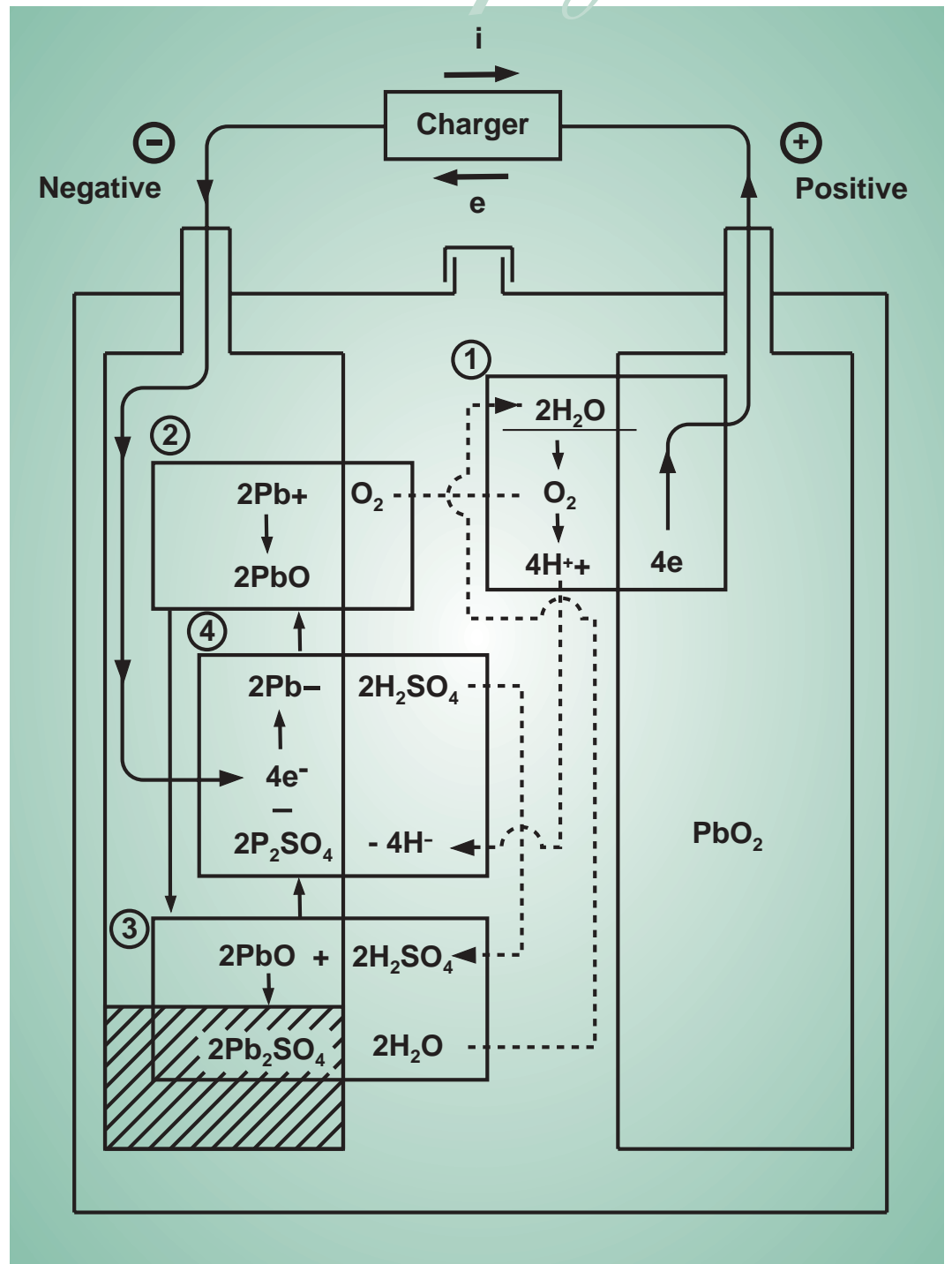

As described above, the oxygen gas generated from the positive plates reacts quickly with the active material in charged condition in the negative plates and returns to water causing very little loss thereof, thus making it possible to build the battery in a sealed construction.

BATTERY MODEL	NOMINAL VOLTAGE (V)	NOMINAL CAPACITY		DIMENSIONS (mm) ± 2 mm				BATTERY WEIGHTS (Kg)	TERMINAL
		TO 1.80V/CELL (AH/10HR)	TO 1.70V/CELL (AH/3HR)	LENGTH	WIDTH	HEIGHT	OVERALL HEIGHT (Inc. Cover)		
EN80-4	4	80	68.7	200	208	234	238	17	8mm STUD
EN80-6	6	80	68.7	200	208	234	238	22	8mm STUD
EN100-4	4	100	85.8	200	208	234	238	17.5	8mm STUD
EN100-6	6	100	85.8	200	208	234	238	23	8mm STUD
EN160-4	4	160	139	206	210	236	240	24	8mm STUD
EN160-6	6	160	139	305	210	236	240	35	8mm STUD
EN320-2	2	320	278	206	210	236	240	24	8mm STUD
EN480-2	2	480	417	305	210	236	240	35	8mm STUD

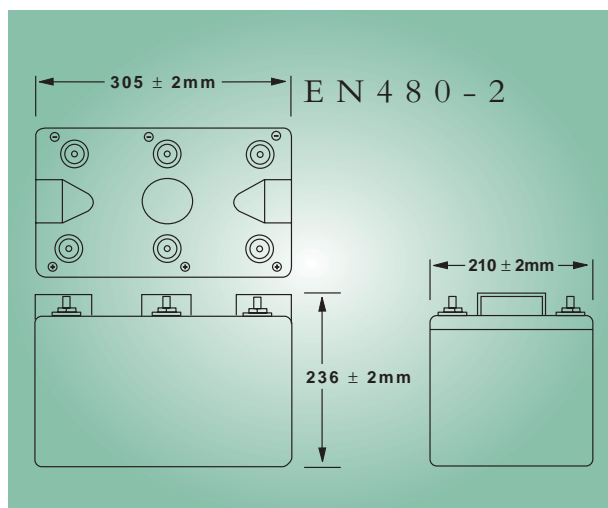
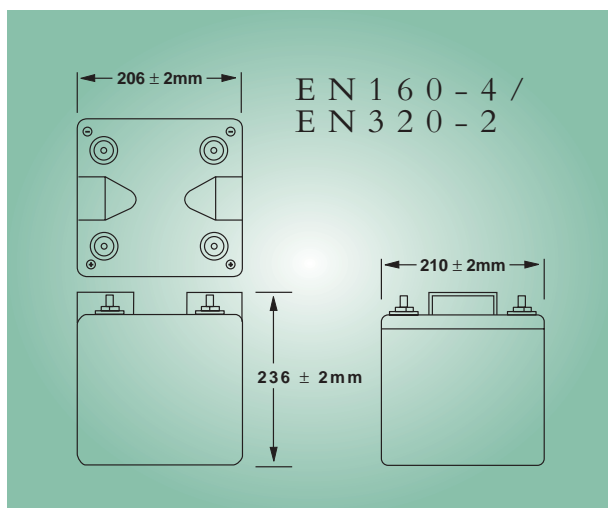
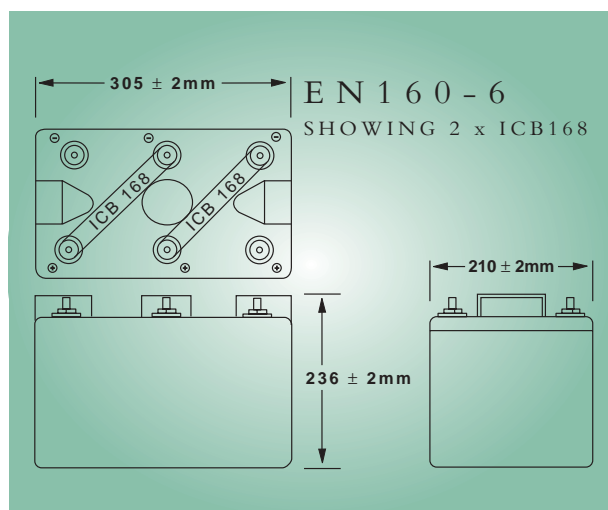
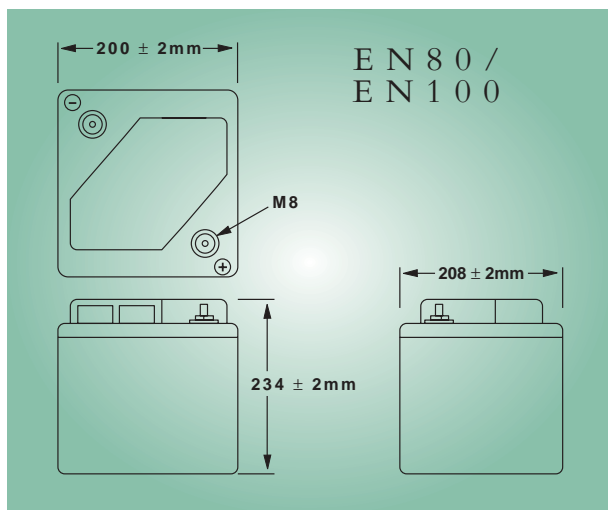

END VOLTS per cell	A M P S / A H 2 0 ° C A U T O N O M Y																		
	MINUTES								HOURS										
	5	10	15	20	25	30	45	1	1.5	2	3	4	5	6	7	8	9	10	24
1.60	3.4	2.4	1.9	1.5	1.3	1.2	.89	.72	.52	.41	.29	.23	.19	.16	.14	.13	.11	.1	.04
1.63	3.3	2.4	1.8	1.5	1.3	1.1	.88	.72	.52	.41	.29	.23	.19	.16	.14	.13	.11	.1	.04
1.65	3.2	2.3	1.8	1.5	1.3	1.1	.88	.71	.51	.41	.29	.23	.19	.16	.14	.13	.11	.1	.04
1.67	3.1	2.3	1.8	1.5	1.3	1.1	.87	.71	.51	.41	.29	.23	.19	.16	.14	.13	.11	.1	.04
1.70	3.1	2.2	1.8	1.5	1.3	1.1	.87	.70	.51	.41	.29	.22	.18	.16	.14	.13	.11	.1	.04
1.75	2.7	2.1	1.7	1.4	1.2	1.1	.85	.68	.5	.39	.28	.22	.18	.16	.14	.12	.11	.1	.04
1.80	2.4	1.9	1.5	1.3	1.1	1	.81	.66	.48	.38	.27	.21	.18	.15	.13	.12	.11	.1	.04
1.85	2	1.6	1.3	1.2	1	.97	.76	.62	.46	.37	.27	.21	.17	.15	.13	.12	.11	.1	.04

Constant current discharge performance data.

Table 2 titled ‘AMPS/AH 20°C’ will allow battery selection to be made for Constant Current load conditions, the table is generic to Endurance batteries and should be used by mapping the required load time to the allowed end of discharge voltage ‘End Volts’. The figure obtained is the Constant Current available for each 1Ah Endurance battery unit, divide this number into the required load and the answer is the battery capacity required to supply the required load.

Example: Load condition 22A constant current.
 Load time 4 hrs.
 Load voltage, nominal 48V to end voltage 40.8V.

1. As lead acid batteries have a nominal single cell voltage of 2V each, divide nominal load voltage by 2 to determine the number of cells required. $48V/2V = 24$.
2. Divide End voltage by the answer to 1 above, to determine End Volts per cell. $40.8V/24 = 1.7$.
3. Map End Volts per cell ‘1.7’ against Load time ‘4 hrs’ answer 0.22.
4. Divide answer 0.22 into Load 22A equals battery capacity required 100(Ah).
5. From Chart 2 select battery model and quantity EN100-6 times 8pcs.

table 3...

END VOLTS per cell	WATTS / CELL / AH											20 °C				
	AUTONOMY											HOURS				
	MINUTES															
	5	10	15	20	25	30	35	40	45	50	55	1	1.5	2	2.5	3
1.60	6.5	4.8	3.8	3.1	2.6	2.3	2	1.8	1.7	1.6	1.5	1.3	0.99	0.79	0.66	0.56
1.63	6.5	4.8	3.8	3.1	2.6	2.3	2	1.8	1.7	1.6	1.5	1.3	0.99	0.78	0.66	0.56
1.65	6.3	4.7	3.8	3.1	2.6	2.3	2	1.8	1.7	1.6	1.4	1.3	0.99	0.78	0.66	0.56
1.67	6.1	4.6	3.7	3	2.6	2.3	2	1.8	1.6	1.6	1.4	1.3	0.98	0.77	0.64	0.55
1.70	5.8	4.4	3.5	3	2.6	2.3	2	1.8	1.6	1.5	1.4	1.3	0.98	0.77	0.64	0.55
1.75	5.4	4.2	3.4	2.9	2.5	2.2	1.9	1.7	1.6	1.5	1.4	1.3	0.96	0.75	0.64	0.54
1.80	4.7	3.7	3.1	2.6	2.3	2	1.9	1.7	1.6	1.5	1.4	1.2	0.93	0.74	0.62	0.53
1.85	4	3.4	2.9	2.5	2.2	1.9	1.8	1.6	1.5	1.4	1.3	1.2	0.89	0.72	0.6	0.52

Constant power discharge performance data.

Table 3 titled 'Watts/Cell/AH 20°C' will allow battery selection to be made for Constant Power load conditions, the table is generic to Endurance batteries and should be used by mapping the required load time to the allowed end of discharge voltage 'End Volts'. The figure obtained is the Constant Power available for each 1Ah Endurance Cell, divide this number into the required load per cell and the answer is the battery capacity required to supply the required load.

Example: Load condition 24Kw dc constant power, 20°C.
 Load time 30min.
 Load voltage, maximum 272V to end voltage 204V.

1. The recommended float voltage for Endurance battery cells (20°C) is 2.26V each, therefore divide maximum load voltage by 2.26 to determine the number of cells required. $272V/2.26V = 120$ cells.
2. Divide End voltage by the answer to 1 above, to determine End Volts per cell. $204/120 = 1.7$
3. Map End Volts per cell '1.7' against Load time '30min' answer 2.1 watts per 1Ah cell.
4. Divide Load condition by cells required to give 'Required Watts per cell'. $24,000/120 = 202.26$.
5. Divide answer 2.1 into Required Watts per cell to find minimum battery capacity required in AmpereHours. $202.26/2.1 = 96.3(Ah)$.
6. From Charts 1 and 2 select battery model/model combination equal or greater than 96.3Ah. Note. As many batteries are supplied in monoblock design, the cell count may need to be divided by the number of cells per monoblock to determine the required quantity of monoblocks.
7. Solution EN100-6 times 40pcs in series.

DISCHARGE

DISCHARGE CHARACTERISTICS

Discharge capacity varies depending on the discharge current (hour rate). The smaller the discharge current, the more the capacity increases, and the larger the discharge current, the less the capacity.

Discharge capacity also varies according to battery temperature. The lower the temperature, the less the capacity.

Fig. 4 shows the constant current discharge characteristics of batteries when they are discharged to the final discharge voltage at various discharge currents at 20°C.

DISCHARGE CHARACTERISTIC CURVE AT 20°C

fig. 4...

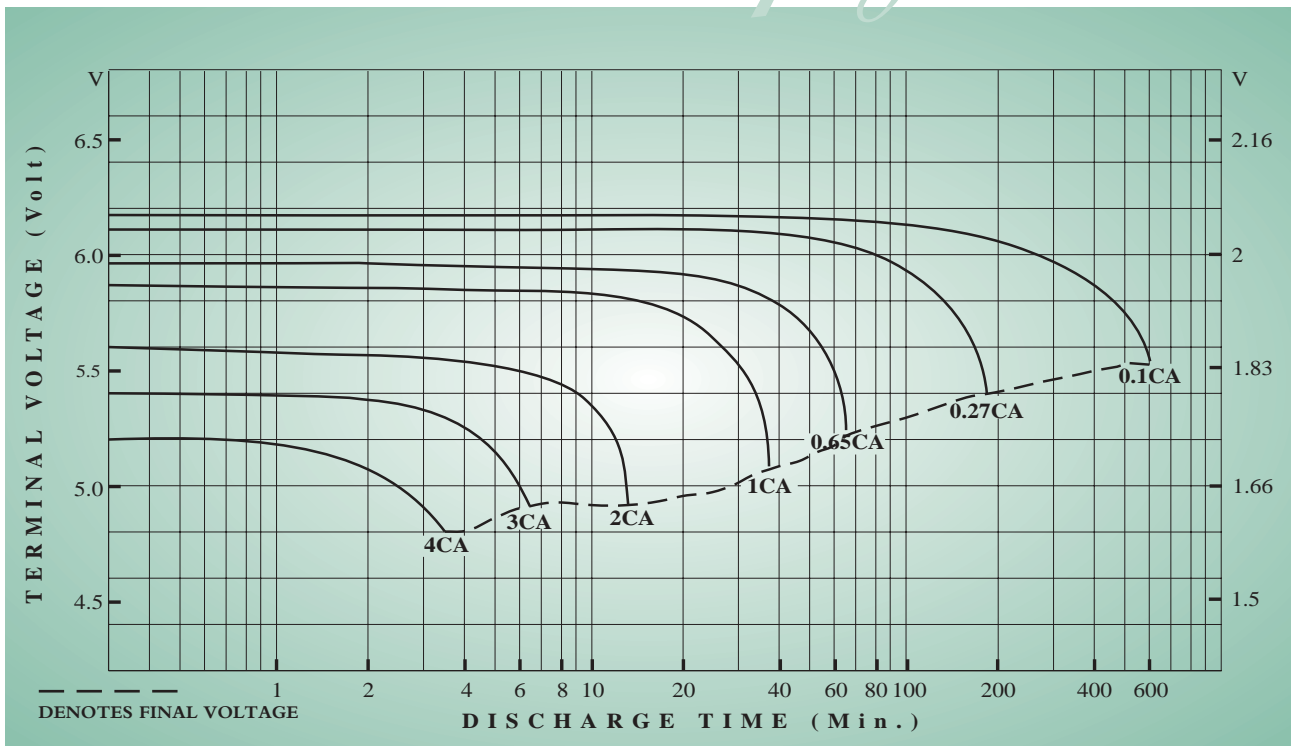
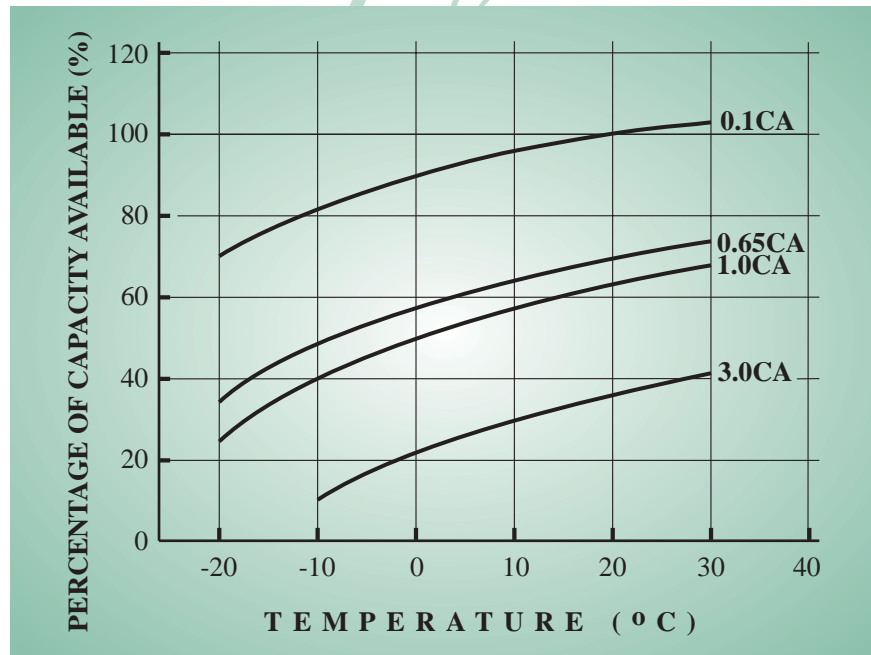

Fig. 5 shows the relationship of temperature with capacity.

For example at 0.1C discharge: a battery capable of discharging for 10 hours at 20°C will decrease the discharge duration to about 8 hours (84%) at -5°C.



CHARGING

CHARGING CHARACTERISTICS

Float charge voltage must be kept at a value high enough to compensate for the battery’s self-discharge to keep the battery in a fully charged condition at all times but low enough to minimise life deterioration due to possible overcharge.

The optimum charge voltage for YUASA Endurance Battery is 2.26V per cell* under normal temperature condition (20°C (68°F)).

The YUASA Endurance Battery requires no equalizing charge. This is because of its low self-discharge rate resulting in a minimal variation among the cells in the battery bank and float charge at sufficient voltage to maintain it in a fully charged condition.

Recovery charge after the battery has been discharged can be carried out at the float charge voltage of 2.26V/cell.*

Fig. 6 shows the charge characteristics at a constant current (0.1C(A)) and constant voltage (2.26V) 10HR rated capacity.

The time required to complete the charging varies by the amount of the previous discharge, initial charge current and temperature.

As shown in Fig. 6 charging a fully discharged battery by constant current and constant voltage of 0.1C(A) and 2.26V* respectively at 20°C will put back more than 100% of the previous discharge in 24 hours.

Since the battery does not restrict the size of initial charge current, making it larger will shorten the time for a charge of more than 100%.

Fig. 7 shows the relationship of charge voltage and current at float charge with gas recombination efficiency.

If the battery is charged at a voltage of 2.26V per cell,* a trickle current just necessary to maintain the battery in fully charged condition will flow at the final stage of charging, and the gas recombination efficiency is maintained at nearly 100%. The final stage current will increase when the temperature is high, and decrease when low.

* Tolerance Range: 2.26V ± 0.005V.

CHARGING CHARACTERISTICS

fig. 6...

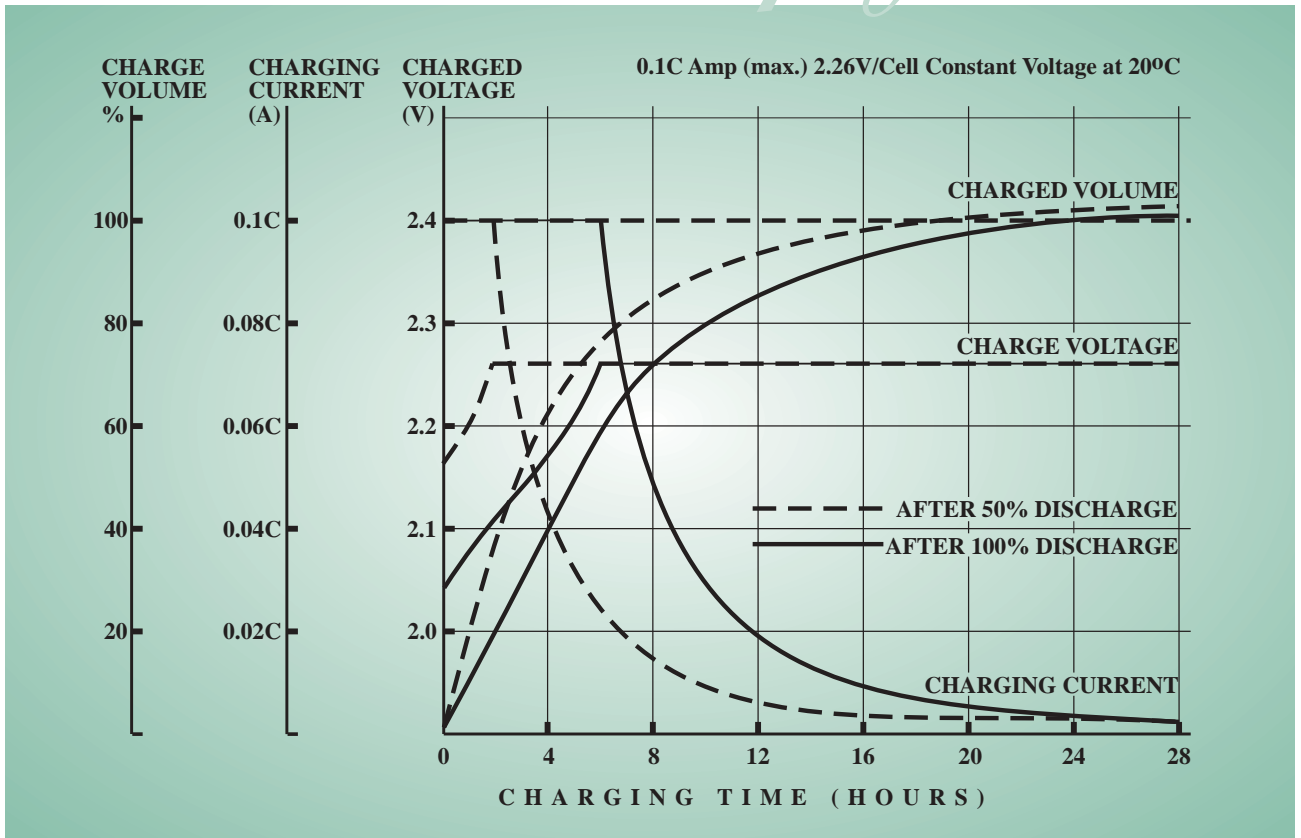

GAS RECOMBINATION EFFICIENCY

fig. 7...

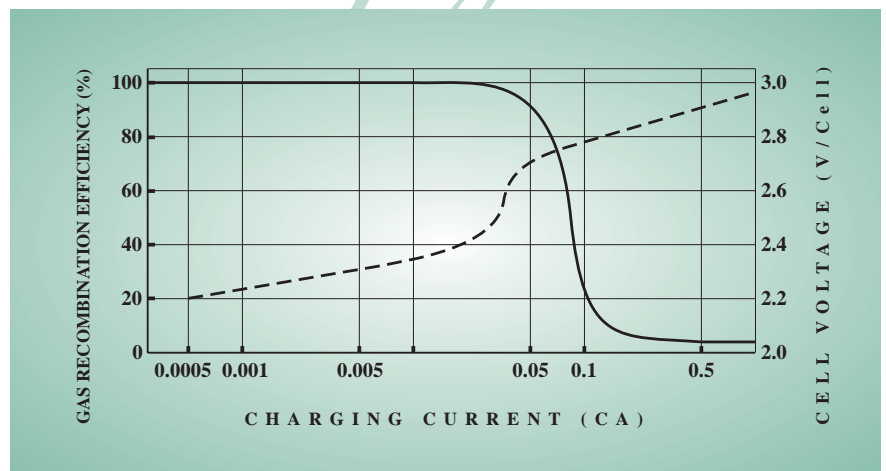

As temperature rises, electrochemical activity in a battery increases and conversely decreases as temperature falls. Therefore, as the temperature rises, the charging voltage should be reduced to prevent overcharge and increased, as the temperature falls, to avoid undercharge. In general, in order to attain optimum service life, the use of a temperature compensated charger is recommended. The recommended compensation factor for EN batteries is $-3\text{mV}/^\circ\text{C}/\text{Cell}$ (for float/standby). The standard centre point for temperature compensation is 20°C . Fig. 8 shows the relationship between temperatures and charging voltages.

In practice where there are short term temperature fluctuations between 5°C and 40°C , temperature compensation is not absolutely essential. However, it is desirable to set the voltage at a value shown in Fig. 8 which, as closely as possible, corresponds to the average ambient temperature of the battery during its service life.

When designing a charger equipped with temperature compensation, the temperature sensor should sense only the temperature of the battery. Therefore, consideration should be given to thermally isolating the battery and temperature sensor from other heat generating components in the system.

Fig. 8...

RELATIONSHIP BETWEEN TEMPERATURE AND CHARGING VOLTAGE

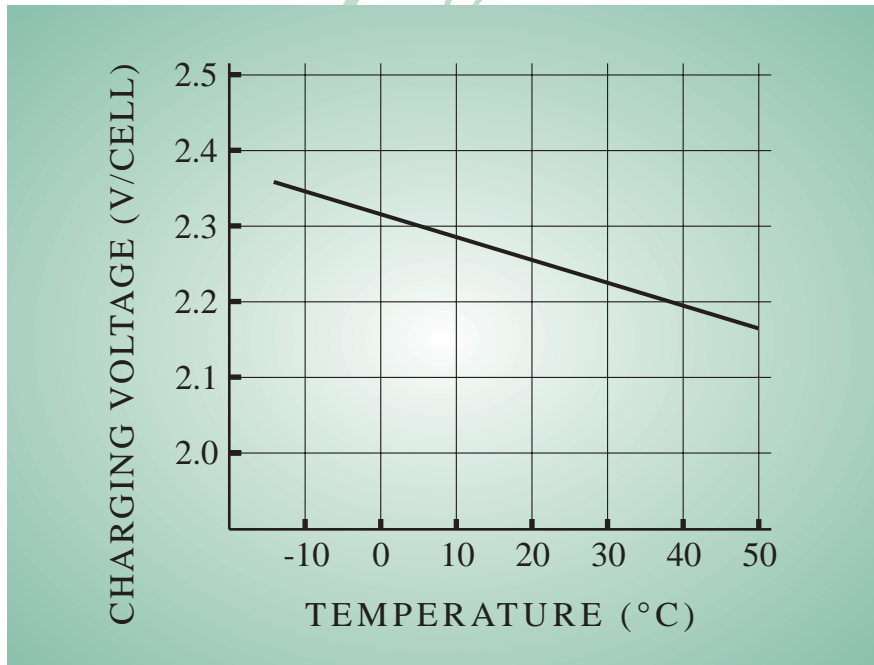

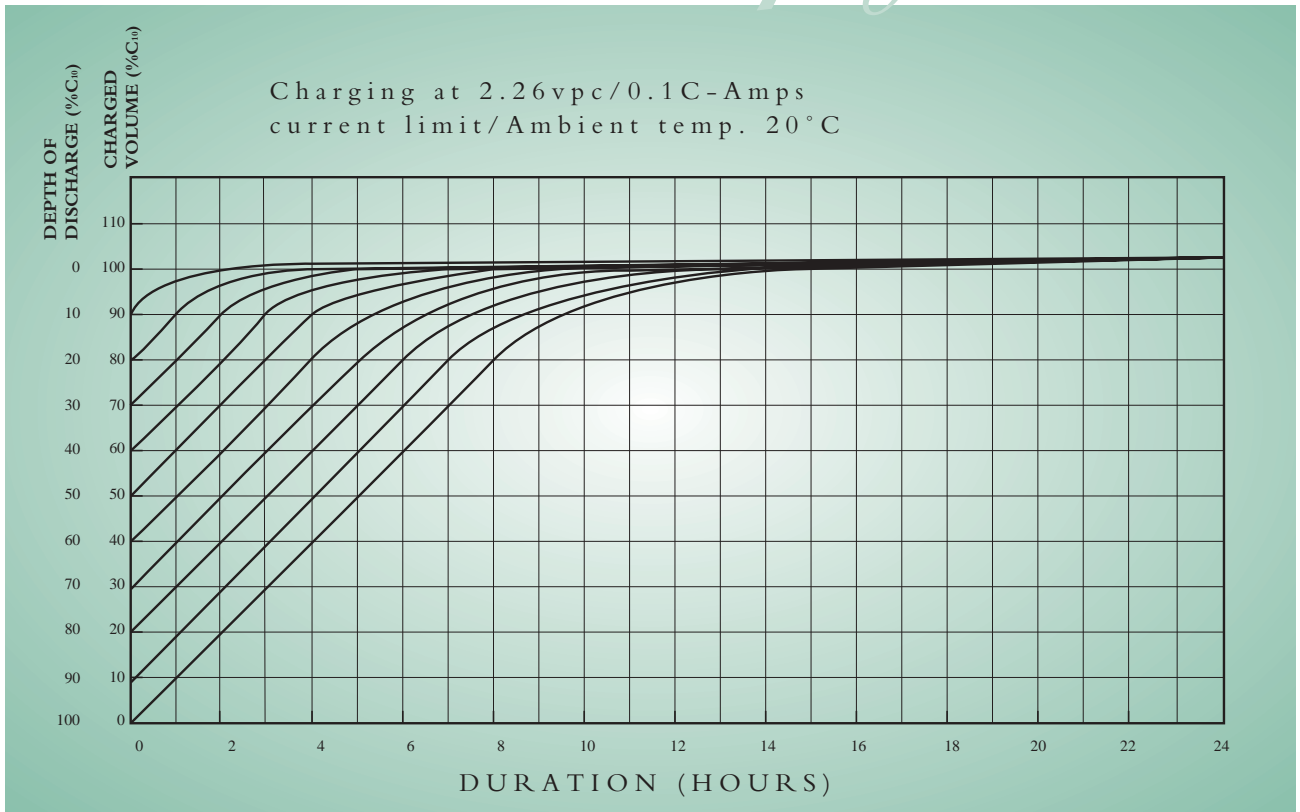

RECHARGE CHARACTERISTICS

When a battery has been subjected to a discharge (i.e. required to support a load), it may be useful to know how long it will take to reach a specified state of charge. This will depend on the following factors: Battery Capacity; Depth of Discharge; Charger voltage and current limits.

An example is given below using figure 9. Charger limits given as 2.26Vpc and 0.1C Amps.

Method	Example
(1) Calculate Discharged Capacity (C)	
(a) Constant Current Load	
Discharged Capacity (Ah) = Current (A) x Time (hrs)	C = 60A x 1hr = 60Ah
(b) Constant Power Load	
Discharged Capacity (Ah) = $\frac{\text{Power (Watts/cell) x Time (hrs)}}{\text{End Voltage (Vpc)}}$	C = $\frac{160Wpc \times 1hr}{1.65Vpc}$ = 97Ah
(2) Calculate Depth of Discharge (DoD)	For EN160Ah
DoD = $\frac{\text{Discharge Capacity} \times 100\%}{\text{Nominal Capacity}}$	DoD = $\frac{97Ah \times 100\%}{160Ah}$ = 60%

From figure 9 read down the left hand axis 'Depth of Discharge' to the calculated value (e.g. 60% DoD in examples (a) and (b) above). Reading across onto the 'Charged Volume Axis' note that when the battery is 60% DoD it is still 40% charged. Trace along the 'Charged Volume' curve until the required state of charge (Charged Volume), is reached.

e.g. Battery will be 80% charged after approx. 4 hours.

Battery will be 95% charged after approx. 7 hours.

This calculation is an approximation only. To be safe it is advisable to add 10% to the calculated time. Therefore in the examples shown the recharge times will be 4 hours 30mins to 80% charged and 7 hours 45mins to 95% charged.

SELF-DISCHARGE CHARACTERISTICS OF ENDURANCE BATTERIES

STORAGE CHARACTERISTICS

The rate of self-discharge is less than 0.08% per day when the battery is left standing at 20°C. As shown in Fig. 10 in storage for one year at 20°C, the capacity decrease is about 29%.

This low rate of self-discharge is because of the use of lead-calcium alloy which is one-fourth to one-fifth that of a battery using lead-antimony alloy.

The higher the temperature, the more the self-discharge, and therefore storage for a long period at elevated temperature should always be avoided.

fig. 10...

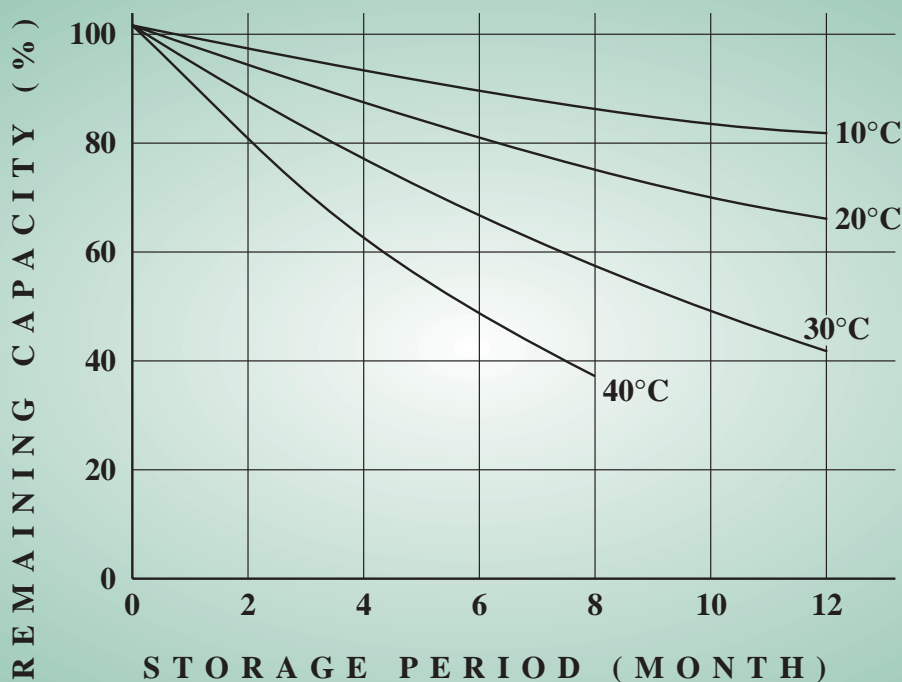

INTERNAL RESISTANCE

The internal resistance (Impedance) of a battery is the lowest when the battery is in a fully charged state. Fig. 11 shows the change in internal resistance of Endurance Batteries during discharge.

INTERNAL RESISTANCE OF ENDURANCE BATTERIES

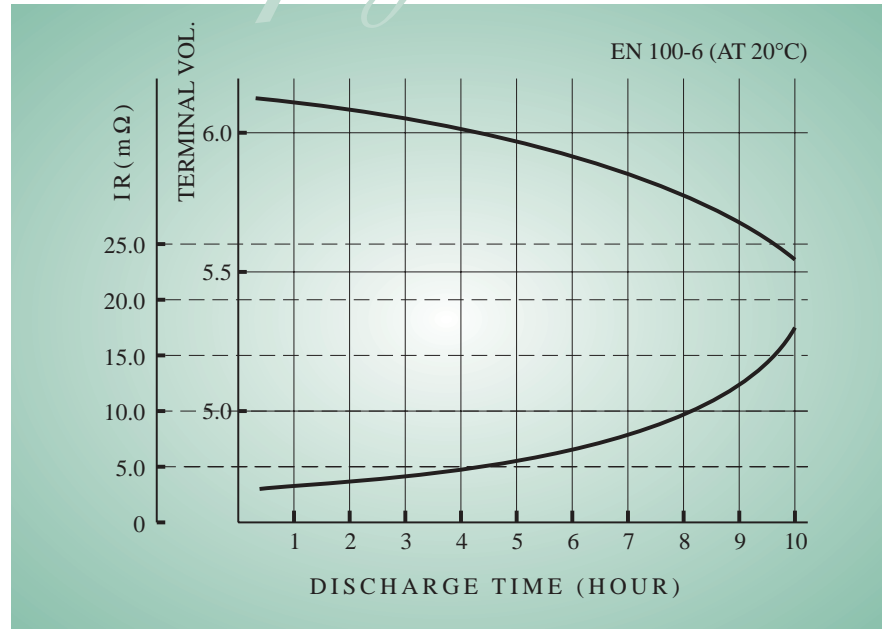

Fig. 11 shows the internal resistance of a battery measured through a 1000Hz AC bridge.

TEST

Impedance testing can be performed using the Yuasa YPI-2 Impedance/comparator test meter, this form of testing is non-intrusive and can be performed online with the battery still connected within its system. (Note: The YPI-2 meter cannot be used where a high AC ripple content exists.) By using this test method deterioration can be detected without removing the battery from its standby mode.

Dedicated literature is available on request.

DESIGN LIFE

LIFE CHARACTERISTICS Within the recommended operating temperature of 15°C-25°C and under optimum float conditions, the service life is expected to exceed 10 years.

The length of float charge life is influenced by discharge frequency, discharge depth, float charge voltage and service environment.

At normal float charge voltage (2.26V per cell), the gas absorption mechanism described previously will have the negative plates absorb the gas generated in the battery returning it into water and, therefore, capacity decrease due to electrolyte depletion will not occur.

Corrosion speed will be accelerated as the temperature rises, making the life shortened. Also the higher the charge current, the faster the corrosion, therefore it is necessary to float-charge the battery at the proper voltage.

The float charge voltage should always be set at 2.26V \pm 0.005V.

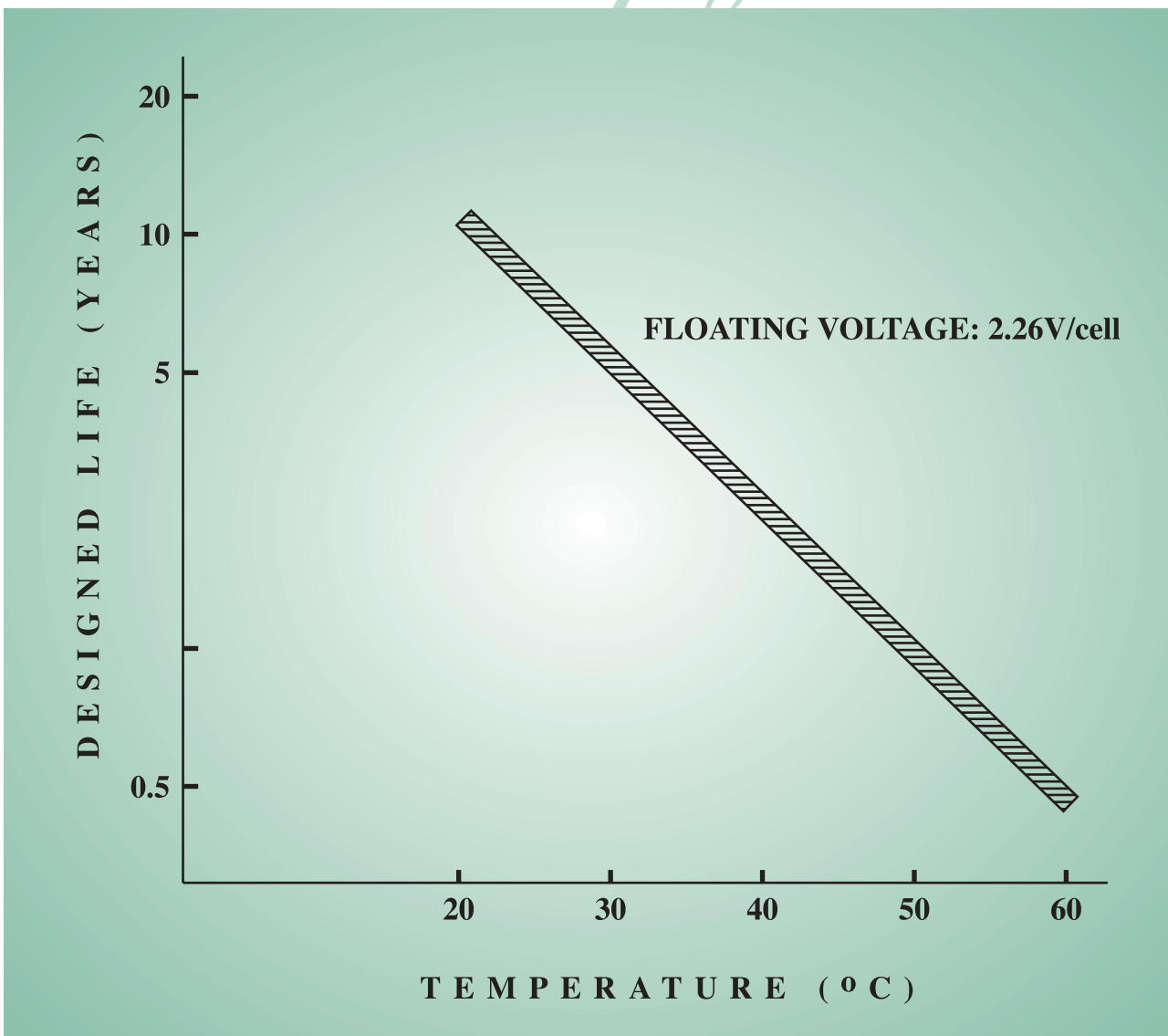

As the result of an accelerated life test by overcharge (at 20°C) in which an overcharge amount corresponding to over 10 year floating charge was given, the capacity decrease was found by about 10%.

Although the battery life in actual service will vary depending on temperatures and other operating conditions, the designed Life of a YUASA Endurance Battery under normal operating conditions (e.g. total discharge amount per month is less than the rated capacity and used under temperatures of 20-30°C) can be estimated as shown in Fig. 12 when the above test data and the life characteristics of conventional stationary lead-acid batteries are taken into account.

RECEIVING The battery is delivered in a charged condition. Please note the following points before installation.

Ignitable gases may be generated from the storage battery. Provide sufficient ventilation and keep the battery away from sparks and naked flame.

Upon arrival, inspect for any damage to the packages, and then unpack them carefully being careful not to damage the battery.

Perform the unpacking at a place adjacent to the battery installation location. Take out the battery by supporting it at the bottom, not by lifting the terminals. Be careful that the seal may be disrupted if the battery is moved with force imposed on the terminals.

After unpacking, check the quantity of accessories and the appearance.

INSTALLATION (1) After verifying no abnormalities in the battery, install it on the prescribed location (e.g. cubicle or battery stand).

(2) If the battery is to be accommodated in a cubicle, place it at the lowest part of the cubicle whenever it is practicable.

(3) When connecting the batteries, free air space must be provided between each battery. The recommended minimum space between batteries is 0.02 inches (5 mm) to 0.04 inches (10 mm).

(4) Always avoid installing the battery close to a heat source (such as a transformer).

(5) Since a storage battery may generate ignitable gases, avoid installing close to any item that produces sparks (such as switch fuses).

(6) Before making connections, polish the joint surfaces of the battery terminals to bright metal by a wire brush.

(7) Apply lightly a rust preventive agent for lead acid storage batteries on connections of the storage battery.

(8) When a multiple number of batteries are used, first make the inter-battery connections in a correct manner, and then connect the battery to the charger or the load.

In these cases, the positive (+) pole of the storage battery should be securely connected to the positive (+) terminal of the charger or the load, and negative (-) to negative (-).

If the storage battery and the charger are connected erroneously, the charger will be damaged. Be sure not to make an erroneous connection.

The tightening torque for each connecting bolt and nut shall be 6.1 Nm (54 lbf. in).

- STORAGE**
- (1) When you wish to store the battery, disconnect it from the charger and load, and store it. If possible, at a dry location with low temperature.
 - (2) If batteries are stored for a long period, give a supplementary charge before service.

- SUPPLEMENTARY CHARGE**
- (1) Part of the battery capacity will have been lost due to self-discharge during transportation or storage. Give supplementary charge before putting into service.
 - (2) The supplementary charge should be given by the following conditions before putting into service.

STORAGE PERIOD	CHARGE VOLTAGE PER CELL	CHARGE TIME	
		MIN	MAX
Not more than 1 Year	2.26V/cell	More than 3 days	
	2.31V/cell	2~6 days	
1~2 Years	2.31V/cell	3~6 days	

MAINTENANCE

A dedicated maintenance guide is available on request.

The guide includes a 'sample' site log sheet for record purposes.

CAUTIONS

- (1) Only clean batteries using a damp cloth. Never allow the battery to be splashed or deposited with oils or organic solvents such as gasoline and paint thinner, nor have it cleaned with cloths impregnated with these materials. Avoid dusting by 'cloth duster' or cleaning by dry cloth (particularly chemical textile) as they will generate static electricity which is dangerous.
- (2) A storage battery may generate ignitable gases. Never place near a naked flame or short circuit the battery.
- (3) If sulphuric acid is deposited due to mechanical damage on to skin or clothes, wash immediately with water.
If splashed into the eyes, wash with a large amount of fresh water and get immediate medical attention.
- (4) DO NOT INCINERATE batteries as they are likely to rupture. Batteries that have reached the end of their service life can be returned to us for safe disposal.
- (5) To obtain optimum service life, the ripple current at R.M.S. should be regulated below 0.1C(A).
- (6) When the storage battery is to be mounted in a container, a ventilation opening should be provided.
Any cubicle or storage room containing batteries should be provided with sufficient ventilation.

- (7) Touching electrically conductive parts may result in a electric shock. Be sure to wear rubber gloves before inspection or maintenance work.
- (8) Heat kills batteries. Avoid placing batteries in close proximity to heat sources of any kind. The longest service life will be attained when the battery is operated around an ambient temperature of 20°C (77°F).
- (9) If 4 or more battery groups are to be used in parallel connection, consult with us prior to use.
- (10) Mixed use of batteries with different histories and of different manufacturer is liable to cause damage to the battery or to the associated equipment. Consult with us if such necessity is present.
- (11) The battery is manufactured from high impact ABS plastic resin, placing it in an atmosphere of, or in contact with organic solvents or adhesive materials should be avoided.
- (12) Do not lift or carry a battery by its terminals.
- (13) Ripple current (the AC component on the DC charge current). Ideally this should be zero, as it will reduce the service life of a cell/battery, the larger the component the greater the reduction it will cause. For example 0.1C Amps R.M.S. will reduce the optimum service life by a minimum 3%.

Note

- I) Ripple current can be source or load generated.
- II) Ripple current can vary with load change and is often its greatest at part load.

INSTALLATION SERVICES

A full range of associated site services is available to support Yuasa customers throughout the UK, these services include:

- ❖ Site surveys.
- ❖ CAD Designed layouts.
- ❖ Installation.
- ❖ Commissioning.
- ❖ Maintenance testing.
- ❖ Battery recovery and safe disposal.

For further details, please contact the Yuasa Technical Services department.

BATTERY RACKS

A wide variety of easy to assemble, sturdy steel battery racks are available to suit your installation requirements, should you require any information about these, or require further assistance regarding battery selection or installation, please contact your nearest YUASA Sales Company.

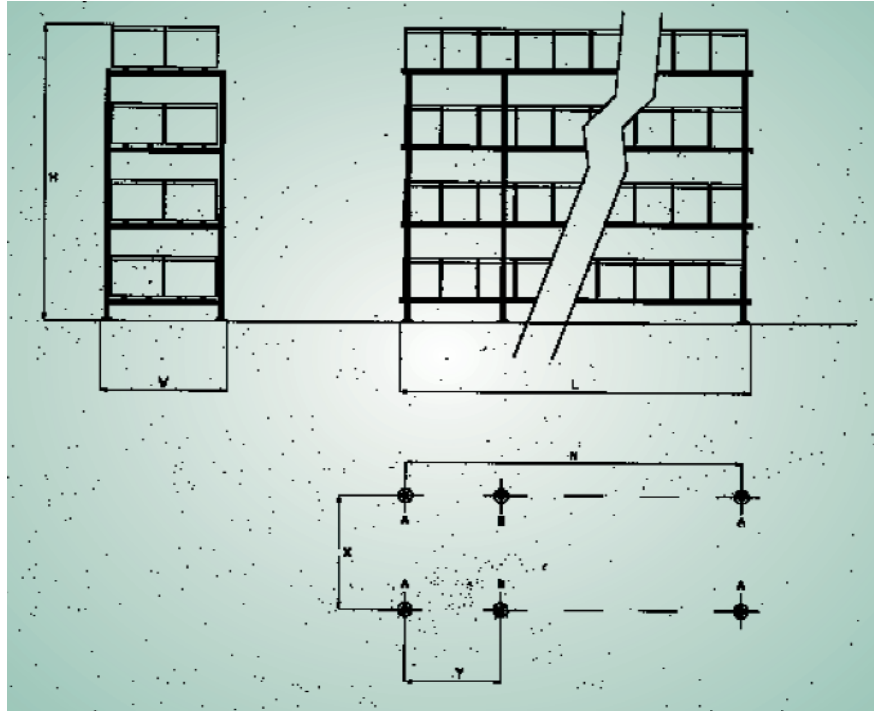

1. **Ampere (A)**..... The unit for measuring the flow of electric current.
2. **Ampere hour (Ah)**... The current in (A amperes) multiplied by time in (h hours). Used to indicate the capacity of a battery.
3. **Capacity (C)**..... Ampere hours that can be discharged from a battery. This unit is relative to time.
4. **Cell**..... The minimum unit of which a battery is composed, consisting of positive and negative plates, separators, electrolyte, etc. In valve regulated lead acid batteries, the nominal voltage is 2 volts per cell.
5. **Charging**..... The process of storing electrical energy in a battery in a chemical form.
6. **Cyclic Service**..... The use of a battery with alternate repetition of charging and discharging.
7. **Cycle Service Life**... The total number of cycles expected at a given depth of discharge.
8. **Deep Discharge**..... (a) Discharge of a battery until 100% of the capacity is exhausted.
(b) Discharge of a battery until the voltage under load drops below the specified final discharge voltage (Over discharge).
9. **Depth of Discharge (DoD)**..... The ratio of discharge capacity vs. the rated capacity of a battery.
10. **Discharge**..... The process of drawing stored energy out of a battery in the form of electrical power.
11. **End Voltage**..... This is the lowest voltage (measured at the leading battery terminals) that the battery can discharge down to while still supporting the Load.
12. **Energy Density**..... The ratio of energy that can be discharged from a battery to the volume of that battery measured in Watt Hours (WH) per cubic inch or litre.
13. **Float Service**..... Method of use in which the battery and the load are connected in parallel to a float charger (or rectifier) so the constant voltage is applied to the battery continuously, maintaining the battery in a fully charged state and to supply power to the load from the battery without interruption or load variation.
14. **Gas Recombination**.. The process by which oxygen gas generated from the positive plates during the final stage of charging is absorbed into the negative plates, reducing the potential at the negative plates, so suppressing the generation of hydrogen.
15. **Impedance**..... The ratio of voltage variation vs. current variation in alternating (a.c.) supply.
16. **Internal Resistance**... The term given to the resistance inside a battery, consisting of the sum of resistance of the electrolyte, the positive and negative plates and separators, etc.
17. **Life Expectancy**..... Expected service life of a battery expressed in total cycles or time in float.

18. **Load**..... The amount of dc electrical power to be supported by the battery, may be expressed as constant current ‘Amps’ or constant power ‘Watts’.
19. **Nominal Capacity**..... The nominal value of rated capacity. In ‘Endurance’ range value regulated lead acid batteries nominal capacity is usually measured at the 10 hour rate.
20. **Nominal Voltage**..... The nominal value of rated voltage. In lead acid batteries, nominal voltage is 2 volts per cell.
21. **Open Circuit Volts**... The voltage of a battery which is isolated electrically from any external circuit, i.e. the voltage is measured in a no load condition.
22. **Parallel Connection**... Connection of a group of batteries by interconnecting all terminals of the same polarity, thereby increasing the capacity of the battery group but not increasing voltage.
23. **Recovery Charge**..... The process of charging a discharged battery to restore its capacity in preparation for subsequent discharge.
24. **Sealed**..... The word ‘Sealed’ is used as a relative term when referring to cells in EN batteries compared with open vented free electrolyte types.
25. **Self Discharge**..... Loss of capacity without external current drain.
26. **Series Connection**... Connection of a group of batteries by sequentially interconnecting the terminals of opposite polarity thereby increasing the voltage of the battery group but not increasing capacity.
27. **Shallow Discharge**... Discharge of a battery in which discharge is less than 50% depth of discharge (DoD).
28. **Shelf Life**..... The maximum period of time a battery can be stored, under specified conditions, without needing supplementary charging.
29. **Standby Service**..... General term for an application in which the battery is maintained in a fully charged condition by trickle or float charging. Synonymous with Float Service.
30. **Trickle Charge**..... Continuous charging by means of a small current designed to compensate for self discharge in a battery which is isolated from any load. For valve regulated lead acid batteries, constant voltage charging is common.
31. **Charged Volume**..... The power returned to the battery by charging as a percentage of the power taken out during discharge.
32. **VCP (vcp)**..... Term for volts per cell.
33. **Watt**..... The SI unit for power, equivalent to 1 joule per second.

E. & O. E.



UNIT 22 RASSAU INDUSTRIAL ESTATE

EBBW VALE, GWENT, NP23 5SD

TEL: 08708 500312 FAX: 08708 500317

WEBSITE: WWW.YUASA-BATTERY.CO.UK

*YUASA BATTERY (EUROPE) GMBH,
TIEFENBROICHER WEG 28, 4000 DÜSSELDORF 30,
TELEFON: (0211) 41790-0, FAX: (0211) 41790-11*

Issue date July 98